

Gebrauchsinformation / Information for use
Information d'emploi / Información de uso

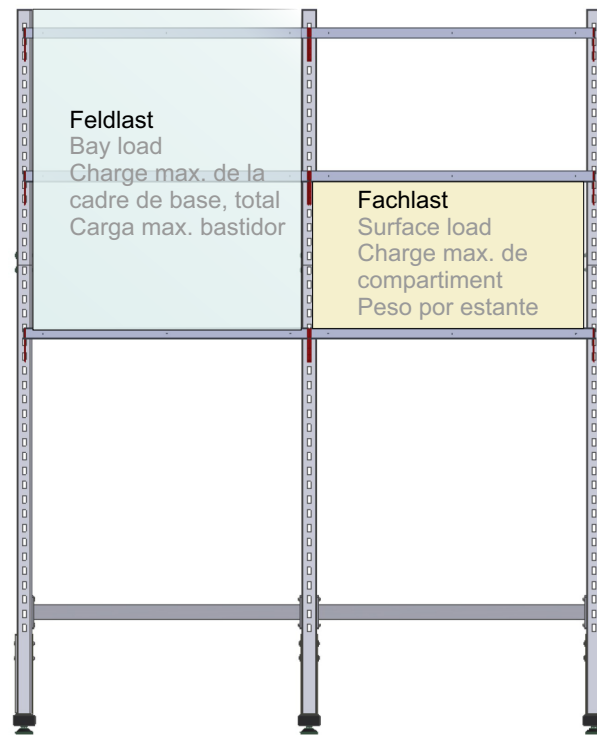

Information
 Information
 Information
 Información

Werden die Ablageböden auch nach Hinten montiert, ist eine Bodenbefestigung notwendig!

If the shelves are also mounted to the rear, a floor mounting is necessary!

Si les étagères sont montées aussi à l'arrière, une fixation par terre est nécessaire!

Una fijación en el suelo es necesario si los estantes son montados hacia atrás!

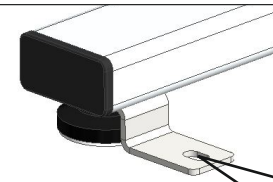

Optionales Zubehör Best.-Nr. Sonder12353
 Optional accessories Ref. Sonder12353
 Accessoires optionnels pour Réf. Sonder12353
 Accesorios opcionales para Ref. Sonder12353

Befestigungsmaterial nicht im Lieferumfang enthalten.
 Fixation material not included.
 Matériel de fixation non inclus.
 Material de fijación no incluido.



Kein Lieferumfang
 No contents
 No contenu
 No incluido

Große Punktlasten, sowie stark einseitige Belastungen sind zu vermeiden. Beim Beladen des Gestelles ist darauf zu achten, dass keine großen dynamischen Kräfte entstehen. (z.B. Kartons auf die Ablageböden werfen)

Bei den Ablagen ohne gesonderte Angaben zur max. Belastung gilt eine max. zulässige Fachlast von 25 kg.

Grundsätzlich gilt eine max. Feldlast von 75 kg.

Avoid large point loads and heavy one-sided loads. While loading the frame, take care that no large dynamic forces are created (e.g. throwing boxes on shelves)

Shelves without separate information have a max. surface load of 25 kg.

In general, a max. bay load of 75 kg applies.

Évitez les charges ponctuelles importantes et les lourdes charges unilatérales. Pendant le chargement du cadre, veuillez à ce qu'aucune force dynamique importante ne soit créée (par exemple en lançant des boîtes sur les étagères).

Les étagères sans information séparée ont un max. charge de surface de 25 kg.

Par Compartiment s'applique un max. charge de 75 kg.

Grandes cargas puntuales y cargas unilaterales son de evitar. Se deben evitar las fuerzas dinámicas al cargar el bastidor (por ejemplo evitar de echar/tirar paquetes sobre los estantes).

La carga máxima por estante sin ninguna otra indicación es de 25 kg.

Básicamente la capacidad de carga es de 75 kg.

Gebrauchsanleitung
Instructions for use
Mode d'emploi
Modo de empleo



SYSTEM FLEX

06/21 93090623

Anbau und Erweiterungsgestelle - gerade, durchgängig
Extension and add-on frames - straight, throughout
Extension et cadres supplémentaires - droit, continu
Bastidor para accesorios - recto y expandible



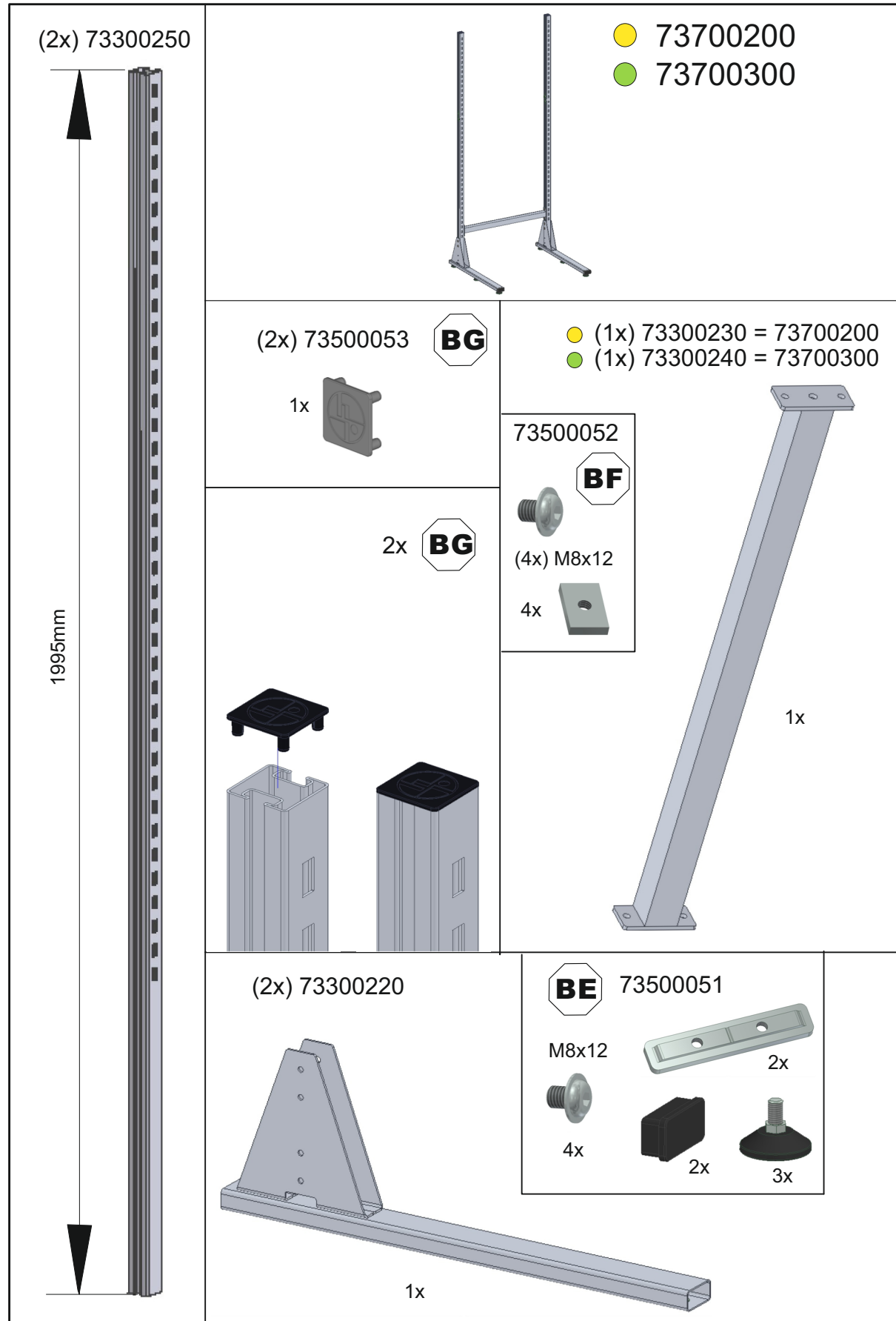
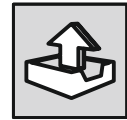

2.

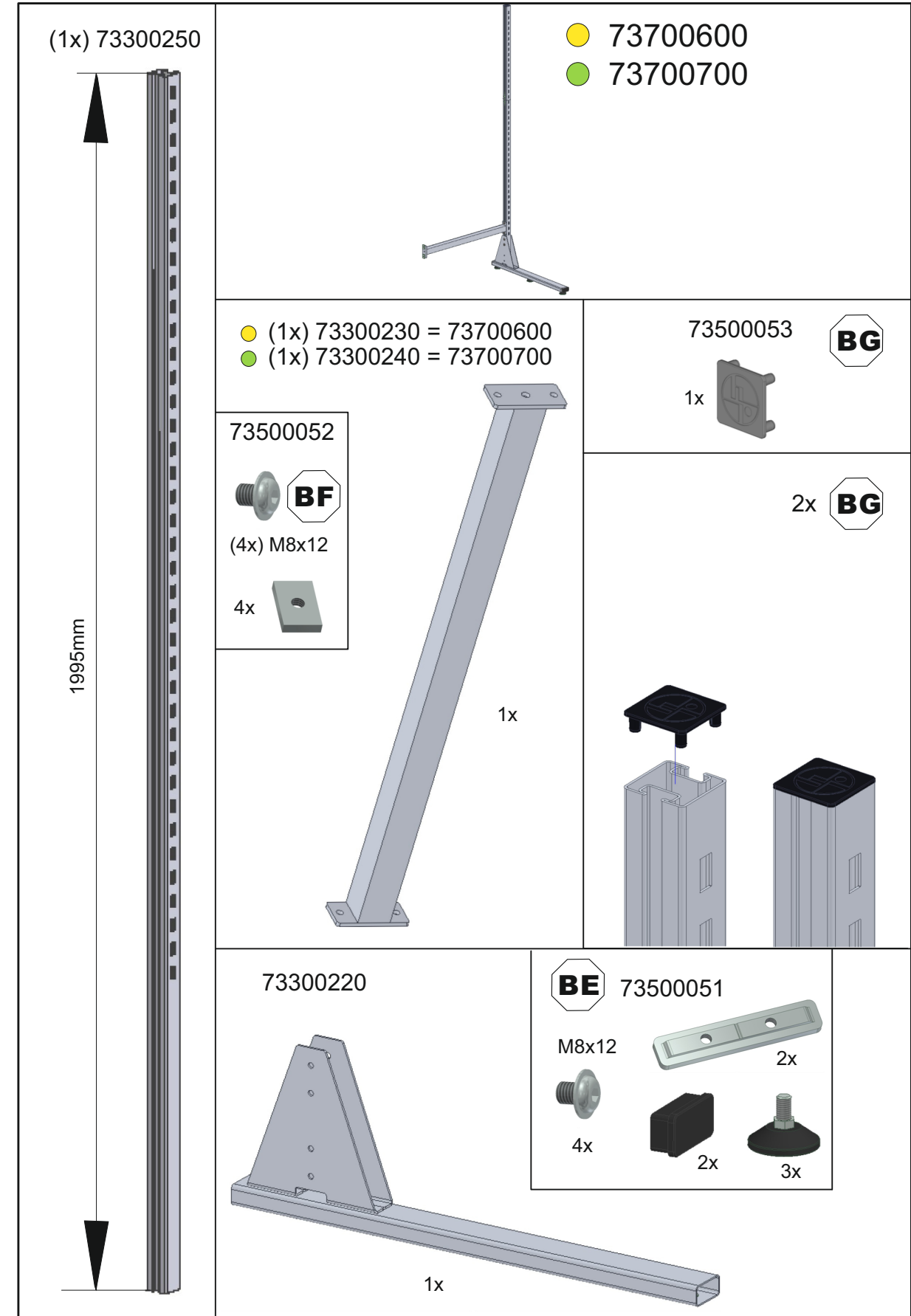
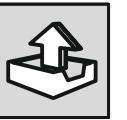

5.



Lieferumfang
Contents
Contenu
Contenido



Montageanleitung
Mounting instructions
Instructions de montage
Instrucciones de montaje



Gebrauchsanleitung
Instructions for use
Mode d'emploi
Modo de empleo

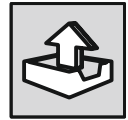
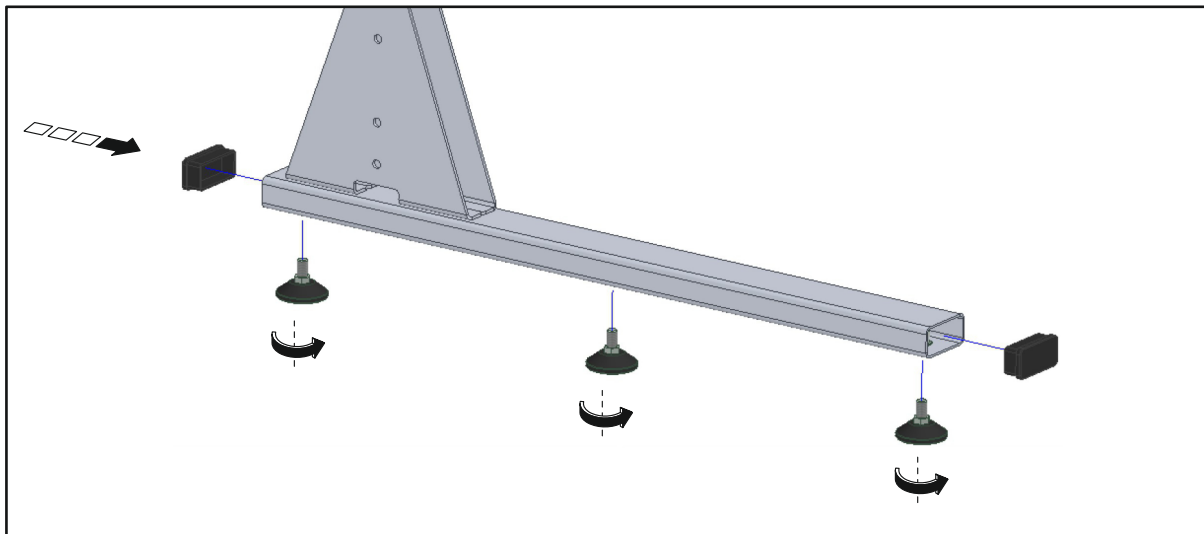

BE

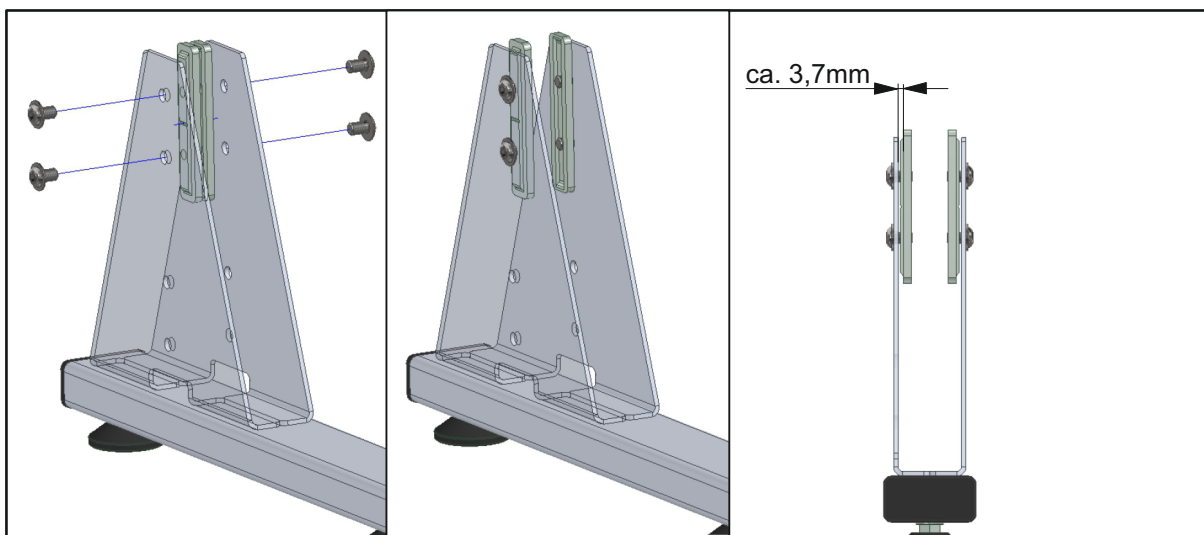

BE

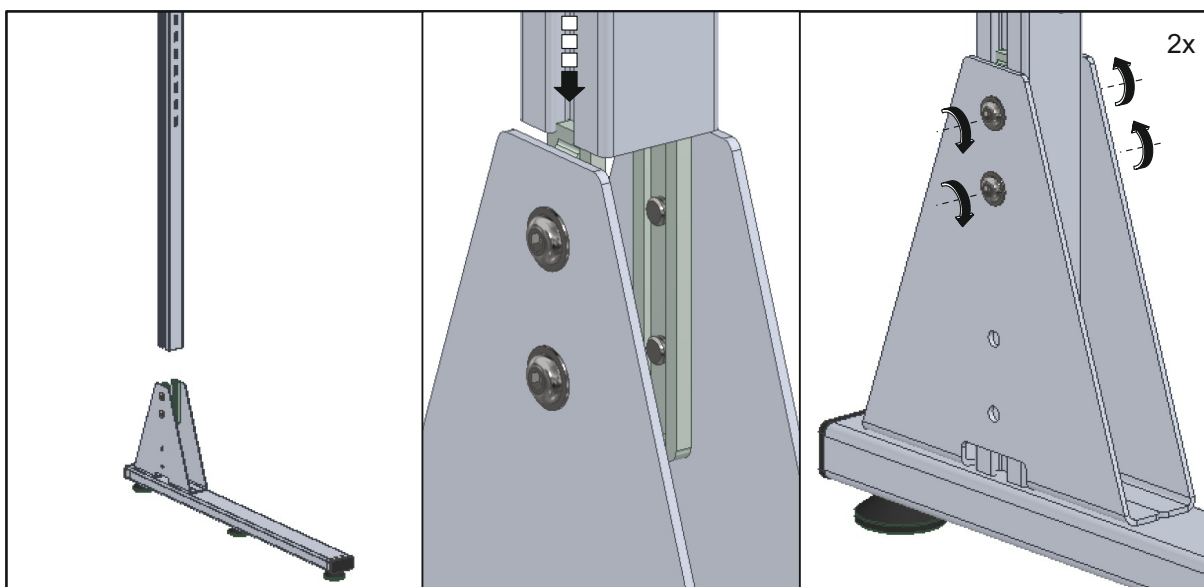

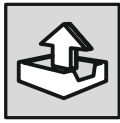

Lieferumfang
Contents
Contenu
Contenido



Montageanleitung
Mounting instructions
Instructions de montage
Instrucciones de montaje



Gebrauchsanleitung
Instructions for use
Mode d'emploi
Modo de empleo

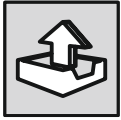

BF

